

BINATROL® DIAPHRAGM BIN MONITOR

- ▼ *Economical, Reliable and Durable
Point Level Detection*
- ▼ *Low Profile Mounting*
- ▼ *Multiple Diaphragm Materials*
- ▼ *Over-Pressure Protection*
- ▼ *Ultra-Sensitive Switch Option*
- ▼ *UL, CSA Approvals*

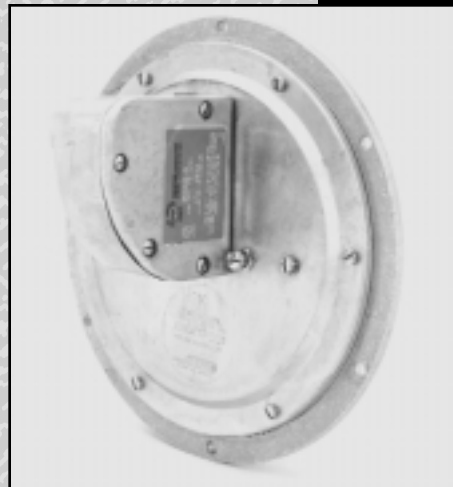

BINATROL®



BULLETIN 623

BINATROL® **MODELS G, GX &** **GX-SS** **DIAPHRAGM** **BIN MONITOR**

- ▼ **Industry's Preferred Diaphragm Unit for 20 Years**
- ▼ **Economical Point Level Detection in Bins and Hoppers**
- ▼ **Ultra-Sensitive Switch for Lightweight Materials**
- ▼ **Unique External Installation and Maintenance**
- ▼ **Multiple Diaphragm Materials**

Monitor's line of BINATROL® diaphragm bin monitors consists of economical, reliable, and durable point level controls for point level detection of dry bulk materials. The units can be used to eliminate bin overflow, maintain a predetermined material level, indicate plugging of chutes or conveyors or provide any of a number of level control functions. The flush mount, non-intrusive BINATROL units are ideally used when vessel size or internal clearance is limited, or where protrusion into a vessel is not acceptable. All installation and servicing, including diaphragm replacement and sensitivity adjustment, can be done from outside the vessel. These products are not normally used with materials which are very light, sticky or of large particle size.

Monitor offers a variety of diaphragm bin monitors that can be configured with various switch sensitivities, diaphragm materials and approval ratings.

PRINCIPLE OF OPERATION

A diaphragm bin monitor provides level indication by detecting pressure applied by the bulk material to the sensing diaphragm. The unit is installed to a vessel wall so that the diaphragm is exposed to the material to be sensed. As material contacts the diaphragm, a force is exerted through the diaphragm to a pressure plate within the bin monitor. Physical deflection of the pressure plate activates an internal switch which is user accessible for signaling alarms, lights or PLC inputs. When material recedes from the diaphragm, a light duty spring returns the pressure plate and internal switch back to their original positions.

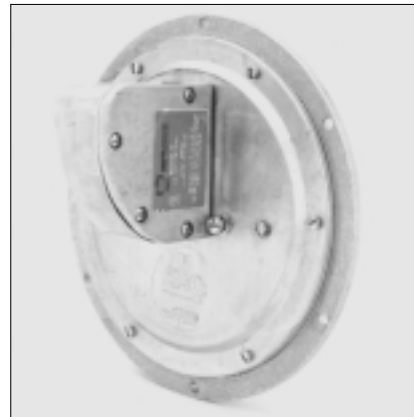

Model G BINATROL® Bin Monitor

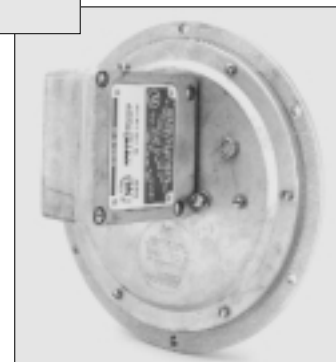

Model GX BINATROL® Bin Monitor

APPLICATIONS

The BINATROL® diaphragm bin monitors can be used to detect high, low and intermediate product levels on dry material storage bins. The BINATROL can be used on either flat or curved surfaces. For bins with a diameter greater than 12' extra gasket materials are not required. For certain applications, the BINATROL can also be used to detect plugged or backed-up conveyor chutes. Depending on the selected options and accessories, these units can be used with light powders, granules, materials with varying particle sizes, pellets, and abrasive and corrosive materials.

SUCCESSFUL BINATROL® APPLICATIONS INCLUDE, BUT ARE NOT LIMITED TO:

- ▼ **Grain**
- ▼ **Wood Chips**
- ▼ **Chemicals**
- ▼ **Powders**
- ▼ **Stucco**
- ▼ **Cement**
- ▼ **Feed Pellets**
- ▼ **Sawdust**
- ▼ **Resin**
- ▼ **Plastic**
- ▼ **Regrind**
- ▼ **Rubber**
- ▼ **Many other applications**



FEATURES

The BINATROL® diaphragm bin monitors offer several unique features that provide key benefits to the user. The following is a brief overview of these features.

SIMPLE DESIGN

The simple design of BINATROL® diaphragm bin monitors provides for maximum ease of use. The BINATROL operates using a “floating” diaphragm, which is free of the electric switch mechanism. Diaphragm movement as little as 1/32” triggers the unit. Also, the BINATROL has no driven parts and thus requires no auxiliary power source. These design features ensure reliable and durable, low maintenance operation.

ADJUSTABLE SENSITIVITY

The BINATROL® offers a sensitivity adjustment that is accessible from outside of the bin and easily adjusted with a screwdriver. This enables the user to adjust the sensitivity of the unit, should vessel contents change, without removing the unit from the vessel.

LOW PROFILE MOUNTING

The low profile mounting of the BINATROL® unit eliminates major protrusions into the bin. This minimizes obstruction of the material flow in the vessel or chute. Also, the beveled-edge construction eliminates any possibility of material lodging.

OVERPRESSURE PROTECTION

The BINATROL® diaphragm bin monitor incorporates a unique sensing plate which provides for overpressure protection. This feature prevents damage to the unit due to heavy loads or forces. In the event that a heavy load is applied to the sensing plate, a mechanical stop prohibits the plate from exerting excessive pressure on the sensitivity spring.

EXTERNAL INSTALLATION/MAINTENANCE

One of the biggest assets of the BINATROL® diaphragm bin monitor is the ability to install and maintain the unit from outside of the vessel. All parts, including the diaphragm are accessible from outside of the bin, without removing the mounting flange. This enables the user to install the unit, change diaphragms and perform basic maintenance without removing the entire unit. For applications which require installation from within the bin, this can also be easily accomplished.

MODELS

MODEL G

The Model G is the most basic BINATROL® diaphragm bin monitor. It provides accurate point level control on most bin types for products ranging from pellets to fine powders.

MODEL GX

The Model GX offers all the features of the Model G, but is specially designed to provide dust-ignition proof protection. This model should be used in applications which require Class II dust-ignition proof approval.

MODEL GX-SS

The Model GX-SS is the dust-ignition proof version of the Model G with a type 321 stainless steel diaphragm. This type of diaphragm provides corrosion resistance when used with corrosive materials such as fertilizer or added protection in abrasive applications. All other features are consistent with Models G and GX.

OPTIONS

DIAPHRAGM MATERIALS

The Model G and GX BINATROL® units are available with two different diaphragm materials.

Standard Diaphragm:

The standard diaphragm is constructed of neoprene and is compatible with most basic applications.

Teflon® Diaphragm:

A Teflon® diaphragm is available for use in high-temp applications. This diaphragm can also be effectively used in sticky applications.

ULTRA-SENSITIVE SWITCH

The Model G, GX and GX-SS units come with a standard SPDT switch. However, for applications involving lightweight materials, Models G and GX can be specified with an ultra-sensitive switch.

ACCESSORIES

HYCAR COVER

Monitor offers a hycar (oil resistant) cover for the diaphragm for watertight applications and to provide additional abrasion resistance. This cover is typically used with Models G and GX.



BULLETIN 623 BINATROL®

ORDERING INFORMATION

	PART NUMBER	DESCRIPTION
Model G:	7-8100	Neoprene diaphragm, standard switch
	7-8101	Neoprene diaphragm, ultra-sensitive switch
	7-8104	Teflon® diaphragm, standard switch
	7-8105	Teflon® diaphragm, ultra-sensitive switch
Model GX:	7-8150	Neoprene diaphragm, standard switch
	7-8153	Neoprene diaphragm, ultra-sensitive switch
	7-8152	Teflon® diaphragm, standard switch
	7-8151	Teflon® diaphragm, ultra-sensitive switch
Model GX-SS:	7-8156	Stainless steel diaphragm, standard switch
Hycar Cover:	7-2009	Hycar diaphragm cover

MECHANICALS

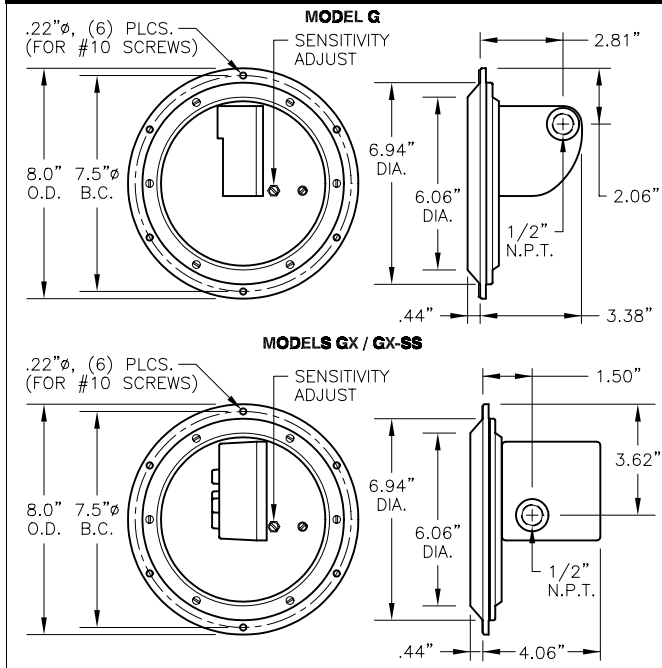

SPECIFICATIONS

Power Requirements:	none
Output:	SPDT dry contact, 15A @ 480 VAC max
Sensitivity:	
GX-SS:	20 lb/ft ³ minimum material density
Standard Switch:	15 lb/ft ³ minimum material density
Extra-Sensitive Switch:	10 lb/ft ³ minimum material density
Enclosure:	die cast aluminum
Enclosure Protection:	NEMA 4, IP56
Mounting Connection:	flange with 7.5" bolt circle
Pressure Rating:	atmospheric pressure only
Wire Entry:	1/2" NPT
Diaphragm Material:	neoprene, reinforced Teflon®, or 321ss (GX-SS only)
Operating Temperature:	
G/GX w/neoprene:	-40° to 180° F
G/GX w/Teflon®:	-40° to 250° F
GX-SS:	-40° to 250° F
Weight:	
G:	2.75 lb
GX, GX-SS:	3.25 lb
Approvals:	G - CSA ordinary locations GX, GX-SS - UL and CSA Class II Div. 1,2 Groups F,G; CE marking
Minimum Vessel Dia.:	12' (Smaller vessels will require modifications and extra gasketing.)

Teflon® is a registered trademark of Dupont Chemical Co.

WARRANTY

Monitor Technologies LLC warrants each BINATROL® diaphragm bin monitor it manufactures to be free from defects in material and workmanship under normal use and service within two (2) years from the date of purchase within North America and one (1) year from date of purchase outside of North America. The purchaser must give notice of a defect to Monitor within the warranty period, return the product intact and prepay transportation charges. The obligation of Monitor Technologies LLC under this warranty is limited to repair or replacement at its factory. This warranty shall not apply to any product which is repaired or altered outside of the Monitor Technologies LLC factory, or which has been subject to misuse, negligence, accident, incorrect wiring by others or improper installation.

Monitor Technologies LLC reserves the right to change the design and/or specifications without prior notice.

HUNTSMAN, INC.
2362 Warren Ave.
Twin Falls, ID 83301

(888) 812-3377 mail@huntsmanc.com

www.huntsmanc.com



Monitor Technologies LLC

44W320 Keslinger Rd. ▼ P.O. Box 8048 ▼ Elburn, IL 60119-8048



623A.3.1100.5M